

Code of Management Practice

Guide for Photo Processors



Recommendations on Technology,
Equipment and Management Practices for
Controlling Silver Discharges from
Facilities that Process Photographic Materials

The Silver Council

The Silver Council

The Silver Council is a national group of trade associations, technical societies, municipalities, and government agencies whose members are vitally affected by the regulation of silver. The Silver Council's purpose is to encourage communications between the regulatory and regulated communities, to support scientific research, and to share current scientific, technical and economic information about silver so that the common goals of pollution prevention, recycling, water conservation, and compliance can be met.

The Silver Council

5454 Wisconsin Avenue
Suite 1510
Chevy Chase, Maryland 20815
Telephone: (301) 664-5150
Fax: (301) 664-5156

This document may be reproduced in its entirety without permission for distribution at no charge to photo processors.

Copyright © 1997 by National Association of Photographic Manufacturers, Inc.

The Code of Management Practice Guide for Photo Processors

The Code of Management Practice Guide for Photo Processors is a set of recommended operating procedures designed to reduce both the amount of silver and the overall volume of solutions discharged to the drain.

Limitations of the Code of Management Practice Guide for Photo Processors

The Code of Management Practice Guide for Photo Processors **does not** supercede existing local regulations. ***Use this Guide only after the local municipality has adopted the Code of Management Practice for Silver Dischargers into regulation.*** Use of this Guide where the Code has not been adopted may cause the photo processor to be out of compliance with local regulations. Before using the Guide, each photo processor should check with the local government agency to determine its regulatory requirements. For more information contact The Silver Council.

Acknowledgements

Many individuals representing the photo processing industry have contributed to the Code of Management Practice Guide for Photo Processors. This Guide is the direct result of their participation in the committee process. We gratefully acknowledge all of these contributions.

The participants volunteered their time and expertise, thus ensuring this Guide provides an approach written *by* photo processors, *for* photo processors. Our thanks to each of these people and their companies. Special thanks go to The Silver Council and the Photo Marketing Association International for funding this project.

Mr. George Champagne, Jr.	Abar Color Labs
Mr. Harvey Fowler, Jr.	Eastman Kodak Company
Mr. Tom Kelly	Ritz Camera Centers
Ms. Tammy Nelson	Konica USA Inc.
Mr. Brian Noble	Noble's Camera Shop
Mr. Jim Noller	Eckerd Corporation
Mr. Herb Stein	Photo Imaging Consultant
Mr. Scott Summers	Eastman Kodak Company
Mr. Ron Willson, Committee Chair	Photo Marketing Association International
Mr. Bert Wilson	Olan Mills, Inc.
Mr. Dick Woolley	Qualex Inc.
Dr. Judith Zaczkowski	Envision Compliance Ltd., Environmental consultant

Table of Contents

Part 1

1.0 Introduction	1
1.1 Regulating Silver	2
a. Concentration-based Limits	2
b. Performance-based Limits	2
A CMP Success Story	3
2.0 Determining the Category	4
Small Photo Processor Worksheet	4
How to Use the Medium and Large Photo Processor Worksheet	6
Medium and Large Photo Processor Worksheet	7
3.0 Small Photo Processors	8
3.1 Compliance Options	8
3.2 Equipment Configurations	8
a. Electrolytic Unit	9
b. One or Two Chemical Recovery Cartridges	10
c. Electrolytic Unit Followed by a Chemical Recovery Cartridge	11
d. Off-site Management	12
4.0 Medium Photo Processors	13
4.1 Compliance Options	13
4.2 Equipment Configurations	13
a. Electrolytic Unit Followed by a Chemical Recovery Cartridge	14
b. Two or More Chemical Recovery Cartridges	15
c. Precipitation Unit	16
d. Evaporation or Distillation Unit	17
e. Off-site Management	18
5.0 Large Photo Processors	19
5.1 Compliance Options	19
5.2 Equipment Configurations	19
a. Electrolytic Unit Followed by Two or More Chemical Recovery Cartridges	20
b. Electrolytic Unit Followed by Precipitation	21
c. Evaporation or Distillation Unit	22
d. Off-site Management	23

Table of Contents

Part 2

1.0	Pollution Prevention	24
1.1	Put a Team Together	25
	a. Management Activities	25
	b. Staff Activities	26
	Pollution Prevention Team Checklist	27
1.2	Review Your Options	28
	a. Management Practices	28
	Preventive Maintenance	28
	Process Control	28
	Inventory Control	28
	Spill Response Planning	29
	Good Housekeeping	29
	Safety and Security	29
	Management Practices Checklist	31
	b. Equipment Modifications	33
	Squeegees	33
	In-line Silver Recovery	33
	Counter-Current Wash Tanks	33
	Low-Flow Wash	33
	Equipment Modifications Checklist	34
	c. Process Modifications	35
	Low Replenishment Chemicals	35
	Solution Regeneration and Reuse	35
	Washless Processing	35
	Water Reuse and Recycling	35
	Dry Chemicals and Automated Mixing	35
	Process Modifications Checklist	36
	d. Solid Waste	37
	Solid Waste Checklist	38
1.3	Develop a P2 Plan	39
	Screening Your Options	39
	Worksheet for Screening Options	39
	Point System	40
	Writing the P2 Plan	40
	Pollution Prevention Plan Worksheet	40
1.4	Put the Plan in Place	41
1.5	Track Your Results	41
	Worksheet for Evaluating P2	41
	Spread the Word	42

Table of Contents

Appendices

Appendix A	Glossary of Terms	43
Appendix B	Electrolytic Silver Recovery	46
Appendix C	Chemical Recovery Cartridges	49
Appendix D	Precipitation	52
Appendix E	Evaporation and Distillation	54
Appendix F	Off-Site Management	55
Appendix G	Ion Exchange	58
Appendix H	Testing for Silver	60
Appendix I	Forms	63
	Small Photo Processor Worksheet	64
	Medium and Large Photo Processor Worksheet	65
	Sample Spill Contingency Plan	66
	Worksheet for Screening Options	67
	Pollution Prevention Plan Worksheet	68
	Worksheet for Evaluating P2	69

1.0 Introduction

Photo processing effluent is a by-product of processing photographic films and papers. After silver recovery, this effluent is generally discharged to the drain where it goes to the publicly owned treatment works (POTW) for treatment, and eventual release back to the environment.

Silver is the component of film and paper that makes it possible to form an image. While it's not an ingredient of fresh photographic solutions, during processing the silver is removed from the film and paper and goes into the solutions. Silver should be recovered from silver-rich solutions before they are discharged to the drain because:

- silver is a non-renewable resource,
- some cities/towns restrict the amount of silver that can be discharged, and
- silver has economic value.

A silver-rich solution is a solution that contains sufficient silver that cost-effective recovery can be done either on-site or off-site. Silver-rich solutions include fix, bleach-fix, stabilizer from washless systems, and low flow wash.

Effective silver recovery requires equipment that is appropriate to the size and activities of the photo processor. It also requires implementing a sound preventive maintenance program. Providing you with this silver recovery information is the primary focus of the Code of Management Practice Guide for Photo Processors.

The Code of Management Practice Guide for Photo Processors is a set of recommended operating procedures designed to reduce both the amount of silver and the overall volume of solutions discharged to the drain.

The other element of the Guide is pollution prevention. In addition to recovering silver efficiently, photo processors should be concerned with minimizing the amount of waste they create. Waste solutions are literally money down the drain. In cases where the solutions can't be discharged to a drain, it costs money for off-site disposal. That's why it makes sense to minimize waste in the first place. The second half of the Guide details several activities a photo processor can undertake to reduce waste and save money.

The Code of Management Practice Guide for Photo Processors is an industry-recommended guide. It is *NOT* a legal requirement. It was written by people just like yourselves — people who manage photo processing labs.

The Guide takes the guesswork out of determining the specific silver recovery configurations and preventive maintenance activities you need. Terms used throughout this Guide are defined in the Glossary of Terms (Appendix A).

1.1 Regulating Silver

Municipal regulators focus on silver and restrict the quantity allowed to be discharged to the drain.

a. Concentration-based limits

The traditional means of restricting silver is to write **concentration-based numerical limits** into the city sewer ordinance. For example, silver may be restricted to 5 parts per million (ppm).^{*} This means that for every million parts of effluent, there can be **no more** than five parts of silver.

Concentration-based limits have been shown to be a poor way to regulate photo processors for several reasons:

1. Our industry strives to conserve water through washless processing, counter-current plumbing, wash water recycling and low replenishment chemicals. As we use less water, the concentration of silver in the effluent increases. Concentration-based limits, therefore, actually penalize those who practice water conservation.
2. Municipal and state sewage treatment authorities ideally develop pretreatment limitations by conducting a study of the POTW waste water coming into the sewage treatment plant and the treated water going out of the plant. Through such a study, they can determine the presence and quantities of pollutants and their removal through the treatment process. The discharge of treated waste water should not impact the water quality of the receiving body of water. Development of pretreatment limitations

^{*} ppm is the same measurement as milligrams per liter (mg/L).

without scientific methods has resulted in widely varied and often unrealistic restrictions across the country.

3. The sampling point used to determine whether or not a limit is being met is determined by the city. It may be the property line manhole or a point where all process waste water is combined. This introduces additional variation from city to city.
4. Our industry's ability to recover silver cost-effectively is dependent upon the equipment available in the marketplace. Restrictions in some jurisdictions are so stringent they can not be met with the best available technology that is economically achievable.

Through the use of this Guide, the photo processing industry, together with the local agency can cooperatively regulate silver discharges to sewer. This Guide offers a uniform approach to regulation from city to city. Most existing restrictions are unachievable given today's technology and the industry goal of conserving water. Even though concentration-based limits are used widely by cities across the country, they are *not* the best way to regulate the photo processing industry.

b. Performance-based limits

Performance-based limits are spelled out as a percentage of the silver that must be recovered from silver-rich solutions. These limits provide environmental protection while taking into consideration the amount of silver-rich solutions generated by the photo processor and the capability of the best available technology (equipment) economically achievable.

Photo processors are grouped into four categories:

- A **small** photo processor is one that produces **less than** *90%* two gallons per day of silver-rich solutions and **no more than** 1,000 gallons per day of total process effluent. Small labs must recover silver to at least 90 percent efficiency.
- A **medium** photo processor is one that produces **more than** *95%* two gallons and **less than** 20 gallons per day of silver-rich solutions and **no more than** 10,000 gallons per day of total process effluent. Medium labs must recover silver to at least 95 percent efficiency.
- A **large** photo processor is one that produces **more than** *99%* 20 gallons per day of silver-rich solutions and **more than** 10,000 gallons per day of total process effluent. Large labs must recover silver to at least 99 percent efficiency.
- A **significant industrial user** (SIU) is one that discharges **more than** 25,000 gallons per day of total process effluent. SIUs have no set percentage recovery efficiency as each SIU is individually permitted by the city.

Performance-based limits are realistic, given the technology currently available to photo processors. Performance-based limits that are uniform across the country would provide a level-playing field for all photo processors and allow the industry to self-regulate. Performance-based limits are the best way to ensure environmental protection while providing economic incentive to the photo processor.

A CMP Success Story

How do you regulate 6,000 photo processors without committing huge amounts of money? That was the problem facing New York City. The economics of enforcing concentration-based limits with limited resources and staff for so many small business locations were enormous. NYC solved its problem in September 1995 by adopting the Code of Management Practice (CMP) for Silver Dischargers. Industry and government then worked together to provide training workshops for photo processors. The workshops demonstrated the advantages of performance-based limits, explained the NYC ordinance and outlined pollution prevention opportunities that processors could incorporate into their business activities. Now, unlike conventional enforcement, NYC inspectors rely on silver recovery efficiency and activity records kept by processors to determine compliance with the city ordinance. New York City expects to divert a significant amount of silver from its sewage treatment facilities and ultimately, from the natural environment.

2.0 Determining the Category

The first step is to determine which of the four categories best describes your lab:

- small
 - medium
 - large
 - significant industrial user (SIU)

Use the worksheet below to see if your photo lab is a **small** photo processor.

A blank copy of this form is included in Appendix I.

If you *are* a small photo processor, skip to Section 3.0 Small Photo Processors.

If you are *not*, turn to the worksheet on page 7 to determine whether you are in the medium or large lab category.

Small Photo Processor Worksheet

Answer as many of the questions as you can. Use your best approximations.

1. How many rolls of film do you process each day?
 [Hint! Count all films disregarding the size. Use roll counts _____ *rolls*
 from the busiest time of year. If you are doing reprints and enlargements or second set of prints, add an additional 20 percent.]

2. How much silver-rich effluent does your lab produce each day?
 [Hint! To obtain this number, use one of these methods: _____ *gallons*
 a) track the number of batches put through the silver recovery unit;
 b) track the volume of bleach-fix, fix, and washless stabilizer mixed;
 c) add the number of waste tanks emptied each day into the silver recovery unit; OR
 d) use replenishment rates for bleach-fix, fix and washless stabilizer multiplied the by average rolls/day.]

3. How much total process effluent does your lab produce each day? _____ *gallons*
 [Hint! To obtain this number, use one of these methods:
 a) track the volume of chemicals mixed and wash water used;
 b) add the number of waste tanks emptied each day; OR
 c) use replenishment rates multiplied by average rolls/day.]

*You are a small photo processor if
 your answer to question #1. is less than 20 rolls/day, AND
 your answer to question #2. is less than 2 gallons, AND
 your answer to question #3. is less than 1,000 gallons.
 ●●● Small photo processors should go directly to page 8 ●●●*

If your numbers are greater than these values for any one question, you are **not** a small photo processor. Use the worksheet on page 7 to determine if you are a medium, large or a SIU photo processor.

If you are not a small photo processor, your next step is to determine whether you fit into the medium, large or SIU category.

Medium photo processors produce **more than** two gallons and **less than** 20 gallons/day of silver-rich solutions, *and less than* 10,000 gallons/day of total process effluent, including wash water.

Large photo processors produce **more than** 20 gallons/day of silver-rich solutions, *and more than* 10,000 gallons/day of total process effluent, including wash water.

Significant Industrial Users (SIU) are not addressed in this Guide. If your photo lab fits into the SIU category, you must operate according to the terms of your discharge permit.

On pages 6 - 7 we've provided you with an example worksheet for categorizing your photo processing lab. The calculations are based on how much replenisher and water are used over a specified period of time. Read through the instructions and look at the example.

A blank copy of this form is included in Appendix I. Make copies of the form to use in your facility and leave the original in this Guide.

How to use the Medium and Large Photo Processor Worksheet

On the start date

1. Write the names of the chemicals you are going to measure in the columns across the top of the chart.
Hint: Group the silver-rich solutions (e.g., fix, bleach-fix and washless stabilizers) on one chart and the low-silver solutions on a second chart.
2. On *line a*, record the date you start measuring the chemicals.
3. Visually check the replenisher tanks for the chemical(s) you are measuring and record the tank volumes on *line d*.
4. Read the water meter and record the number on *line s*. If your water meter measures cubic feet, multiply the usage by 7.48 to convert cubic feet to gallons. **Hint:** The last digit should be 1/10ths. (This position is stationary on some meters.) If you don't have a water meter simply use your water bill to determine water consumption for a period of one month. If you're still not sure, ask your water supplier for help.

During the check period

5. Throughout the check period, record the volume of each of the chemicals mixed using *line e* through *line n*. **Hint:** Write the amount down each time you mix so you don't forget to do it.

On the end date

6. Write down the end date on *line b*.
7. On *line c*, record the number of days during that period the lab was actually processing.
8. Visually check the replenisher tanks for the chemical(s) you are measuring and record the tank volumes on *line p*.
9. Read the water meter and record the number on *line t*. If applicable, convert cubic meters to gallons.
10. To determine total water usage on *line u*, do the following calculation: *line t* minus *line s* minus *the domestic flow portion of the water*. **Hint:** Since we're only considering processing effluent, you must subtract the domestic flow portion of the water used (e.g., bathrooms, sinks, etc.). Multiply the number of employees x 20 gallons of water per day (for every day of operation). Subtract this number from the total water usage. (e.g., 10 employees x 20 gallons x 25 days [of operation] = 5,000 gallons)
11. To determine average water usage divide *line u* by *line c*. Enter the number in *line v*.
12. Add *line e* through *line n* (the amount of chemicals mixed) and record the number on *line o*.
13. Add *line o* to *line d* and subtract *line p* (the total volume mixed plus the volume in the replenisher tank at the beginning of the period, minus the volume left in the replenisher tank at the end of the period). Write this number in *line q*.
14. Calculate the average chemicals used per day by dividing *line q* by *line c* (the chemical volume used divided by the number of days in the period). Write this number in *line r*.
15. Add all the numbers across the columns in *line r* for silver-rich solutions. Enter the number in *line w*.
16. Add low-silver solutions plus water usage (*line v*) plus silver-rich solutions (*line w*). (The volume of low-silver solutions should be tracked on a separate worksheet.)

Medium and Large Photo Processor Worksheet

The volume of silver-rich and low-silver solutions discharged to the POTW can be estimated by measuring the amount of replenisher and water used during a specific time period. Use this chart along with the instructions to calculate waste. In this example, we've tracked silver-rich solutions and water only. Use a separate sheet for low-silver solutions.

Example Chart	Chemical Names			
	Film Fixer	Film Stabilizer	Paper B/F	Paper Stab
a) Start date (day/month)	June 1	June 1	June 1	June 1
b) End date (day/month)	June 30	June 30	June 30	June 30
c) Working days (a - b - the number of days closed)	25	25	25	25
d) Replenisher tank volume on start date (in gallons)	15	12	17	10
e) 1st mix volume (in gallons)	25	25	25	25
f) 2nd mix volume	25	25	25	25
g) 3rd mix volume	25	25	25	25
h) 4th mix volume	25	25		25
i) 5th mix volume		25		25
j) 6th mix volume				25
k) 7th mix volume				
l) 8th mix volume				
m) 9th mix volume				
n) 10th mix volume				
o) Total volume mixed [e + f + g ... + n] (in gallons)	100	125	75	150
p) Replenisher tank volume on end date (in gallons)	20	5	8	15
q) Chemical volume used (d + o) - p	95	132	84	145
r) Average chemical volume discharged (q ÷ c)	3.8 gal	5.28 gal	3.36 gal	5.8 gal
s) Water meter reading on start date (in gallons)	34812 gal			
t) Water meter reading on end date	52012 gal			
u) Water usage (t - s - domestic flow of 5000 gallons)	12200 gal			
v) Average water usage (u ÷ c)	488 gal			
w) Total all the numbers recorded across in line r for silver-rich solutions only	$3.8 + 5.28 + 3.36 + 5.8 = 18.24$ gallons			
x) Total all the numbers recorded across in line q for low-silver solutions plus line v (average water usage)	<u>gallons of low-silver solutions + 488 + 18.24 = total gallons of process effluent</u>			

A **medium** photo processor produces **more than** two gallons and **less than** 20 gallons/day of silver-rich solutions (*line w*), and **more than** 10,000 gallons/day of total process effluent (*line x*), including wash water. If you fit this category, turn to page 12.

A **large** photo processor produces **more than** 20 gallons/day of silver-rich solutions (*line w*), and **more than** 10,000 gallons/day of total process effluent (*line x*) including wash water. If you fit this category, turn to page 18.

3.0 Small Photo Processors

A small photo processor is one that produces less than 2 gallons per day of silver-rich solutions and no more than 1,000 gallons per day of total effluent. Small labs must recover silver to at least 90 percent efficiency.

This section includes the following information for **small** photo processors:

- silver recovery compliance options, and
- equipment configurations with testing and record keeping requirements.

3.1 Compliance Options

The following silver recovery options are recommended for recovering at least 90 percent of the silver from silver-rich solutions:

1. electrolytic unit, or
2. one or two chemical recovery cartridges (CRCs) with manufacturer-specified flow control,* or
3. electrolytic unit followed by a chemical recovery cartridge (CRC) with manufacturer-specified flow control, or
4. off-site management, or

* Facilities that generate less than 0.5 gallons per day of silver-rich solutions need only one CRC. Due to the low volume, a second CRC would oxidize and channel by the time the first CRC was exhausted resulting in no additional silver recovery.

5. alternative technology providing at least 90 percent silver recovery.

3.2 Equipment Configurations

In this section for small photo processors, we'll review typical silver recovery equipment configurations for each of the compliance options. Detailed information is available in the appendices.

We'll also describe the testing methods and procedures to use with the equipment to verify that it is recovering at least 90 percent of the silver.

Finally, we'll show you samples of simple silver recovery logs to use for recording the results of the testing.

If you are a small photo processor, you **must select and use** one of the equipment configurations discussed in this section.

For detailed information about a specific type of silver recovery equipment, how it works, and preventive maintenance recommendations, refer to:

Appendix B Electrolytic Silver Recovery
 Appendix C Chemical Recovery Cartridges
 Appendix F Off-Site Management

a. Electrolytic unit

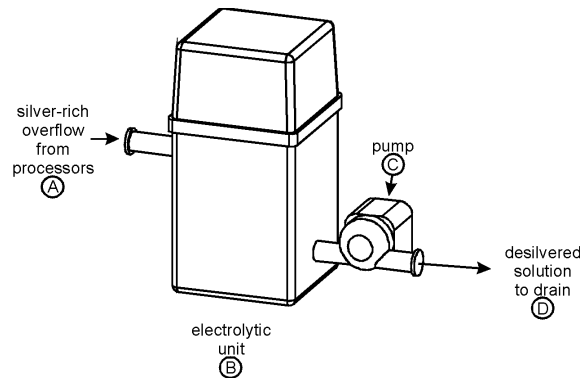

How it works

In this configuration, the silver-rich overflow from the processor (A) is directed to the electrolytic unit (B). When sufficient silver-rich solution has accumulated, the electrolytic unit begins to desilver the solution. When the batch is completed, the desilvered solution is pumped (C) out of the electrolytic unit to the drain (D).

Testing methods

There are two types of testing methods you must use:

- **once each week**, silver-estimating test papers or another method of approximating silver must be used to indicate the system is working, (pass/fail), and
- **once every year**, highly accurate analytical laboratory testing such as atomic absorption (AA) or inductively coupled plasma spectroscopy (ICP) must be used. Use an outside service for analytical testing. Review Appendix H for detailed information about testing.

Testing procedures

Use the following testing procedures with this equipment configuration:

1. The solution coming out of the electrolytic unit (D) must be checked **weekly** with silver-estimating test papers. (See Appendix H for more information.)
2. The solution going into the electrolytic unit (A) and coming out of the electrolytic unit (D) must be tested **once every year** by an analytical laboratory. This testing is used to verify the percent efficiency of the system.

Testing records

- All test results must be recorded in a silver recovery log. See the examples below. Check with the POTW to find out how long to keep records on file.

Silver Recovery Log	
Date	Weekly Effluent Check*
	Electrolytic
7/1/96	P
7/8/96	P
7/15/96	P

* Pass (P) = no color, Fail (F) = color

Silver Recovery Log (ppm)			
Date	Annual Test		%
	Influent	Effluent	Recovery
7/1/96	1984	186	90.6%*
7/1/97			
7/1/98			

* To obtain the percent recovery, use the following formula:
 $100 - (\text{effluent} \times 100 \div \text{influent})$.

b. One or two chemical recovery cartridges (CRCs) with manufacturer - specified flow control

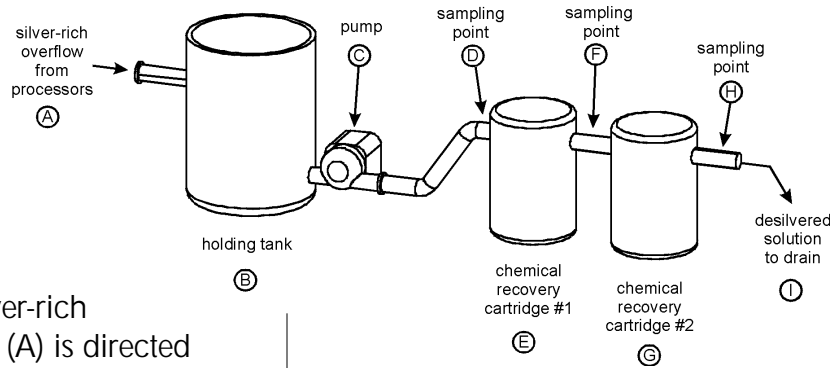

How it works

In this configuration, the silver-rich overflow from the processor (A) is directed to the holding tank (B). Next, it is metered (C) at a fixed rate through the chemical recovery cartridges (CRCs) set up in series (E - G). In this diagram two CRCs are shown. Once the solution exits the last cartridge in series (H) at least 90 percent of the silver has been recovered and the solution can be discharged to the drain (I).

Testing methods

There are two types of testing methods you must use:

- **once each week**, silver-estimating test papers or another method of approximating silver must be used to indicate the system is working (pass/fail), and
- **once every year**, highly accurate analytical laboratory testing such as atomic absorption (AA) or inductively coupled plasma spectroscopy (ICP) must be used. Use an outside service for analytical testing. Review Appendix H for detailed information about testing.

Testing procedures

Use the following testing procedures with this equipment configuration:

1. The solution coming out of the first CRC (F) must be checked **weekly** with

silver-estimating test papers. (See Appendix H for more information.)

2. At the same time, the solution coming out of the last CRC(H) must be checked **weekly** with silver-estimating test papers.
3. The solution going into the first CRC (B) and coming out of the last CRC (H) must be tested **once every year** by an analytical laboratory. This testing is used to verify the percent efficiency of the system.

Testing records

- All test results must be recorded in a silver recovery log. See the examples below. Check with the POTW to find out how long to keep records on file.

Silver Recovery Log		
Date	Weekly Effluent Check*	
	CRC #1	CRC #2
7/1/96	P	P
7/8/96	P	P
7/15/96	F	P

* Pass (P) = no color, Fail (F) = color

When the weekly check indicates cartridge failure, refer to the equipment manual for the manufacturer's recommendations.

Silver Recovery Log (ppm)			
Date	Annual Test		% Recovery
	Influent	Effluent	
7/1/96	1784	176	90.1%*
7/1/97			
7/1/98			

* To obtain the percent recovery, use the following formula:
 $100 - (\text{effluent} \times 100 \div \text{influent})$.

c. *Electrolytic unit followed by a chemical recovery cartridge (CRC) with manufacturer -specified flow control*

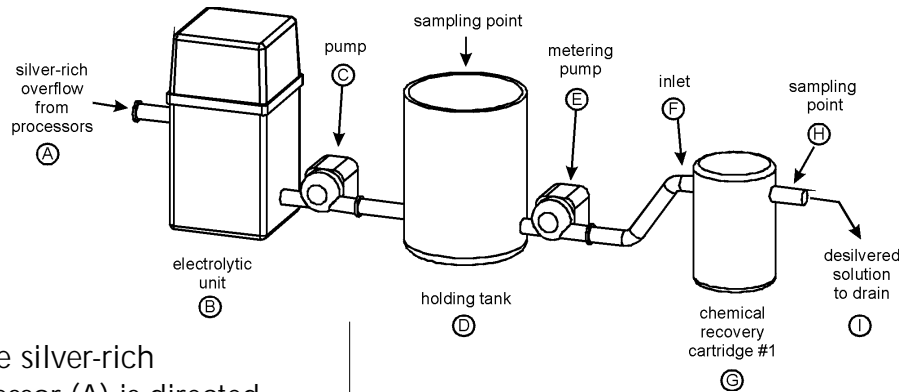

How it works

In this configuration, the silver-rich overflow from the processor (A) is directed to the electrolytic unit (B). When sufficient silver-rich solution has accumulated, the electrolytic unit begins to desilver the solution. When the batch is completed, the partially desilvered solution is pumped out of the electrolytic unit (C) into the holding tank (D). From here, it is metered (E) at a fixed rate through the chemical recovery cartridge (G). Once the solution exits the cartridge (H) at least 90 percent of the silver has been recovered and the solution can be discharged to the drain (I).

Testing methods

There are two types of testing methods you must use:

- **once each week**, silver-estimating test papers or another method of approximating silver must be used to indicate the system is working, (pass/fail), and
- **once every year**, highly accurate analytical laboratory testing such as atomic absorption (AA) or inductively coupled plasma spectroscopy (ICP) must be used. Use an outside service for analytical testing.

Testing procedures

Use the following testing procedures with this equipment configuration:

1. The solution coming out of the electrolytic unit (D) must be checked **weekly** with silver-estimating test papers. (See Appendix H for more information.)
2. The solution coming out of the CRC (H) must be checked **weekly** with silver-estimating test papers.
3. The solution going into the electrolytic unit (A) and coming out of the CRC (H) must be tested **once every year** by an analytical laboratory. This testing is used to verify the percent efficiency of the system.

Testing records

- All test results must be recorded in a silver recovery log. See the examples below. Check with the POTW to find out how long to keep records on file.

Silver Recovery Log		
Date	Weekly Effluent Check*	
	Electrolytic	CRC
7/1/96	P	P
7/8/96	P	P
7/15/96	P	F

* Pass (P) = no color, Fail (F) = color

Silver Recovery Log (ppm)			
Date	Annual Test		% Recovery
	Influent	Effluent	
7/1/96	1984	186	90.6%*
7/1/97			
7/1/98			

* To obtain the percent recovery, use the following formula:
 $100 - (\text{effluent} \times 100 \div \text{influent})$.

d. Off-site management

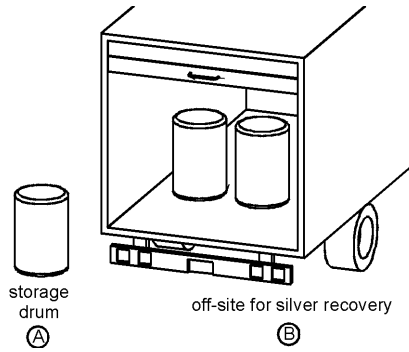

How it works

In this configuration, the silver-rich solution overflow from the processor is stored in a drum (A) until it is picked-up by a licensed hauler for off-site silver recovery, treatment and/or disposal (B).

Testing requirements

There are no Code of Management Practice testing requirements for verifying silver recovery efficiencies. State waste agencies, however, may require testing in order to characterize the waste.

Additional requirements

Photo processors using off-site management must meet the following requirements:

- Submit notification to the local sewage treatment authorities (e.g., POTW) that the processor is using off-site silver recovery. The POTW may require some specific information concerning the hauling company and receiving facility.
- Store the silver-rich solutions in a drum that's compatible with photo processing solutions.

- Provide secondary containment for storage tanks, if required in your jurisdiction.
- Comply with all applicable hazardous waste and DOT regulations.
- Keep records of volumes and types of solutions transferred off-site. See the example log below.
- Maintain logs and records for at least three years. Make the records available for inspection by the sewage treatment authorities.

Date	Amount (gallons)	Type of Solution	Manifest Number
2/6/96	44	silver - rich photo	MI 3084201
3/5/96	44	silver - rich photo	MI 3084202
4/2/96	55	silver - rich photo	MI 3084203
5/7/96	48	silver - rich photo	MI 3084204
6/4/96	55	silver - rich photo	MI 3084205

4.0 Medium Photo Processors

A medium photo processor is one that produces more than 2 gallons and less than 20 gallons per day of silver-rich solutions and no more than 10,000 gallons per day of total effluent. Medium labs must recover silver to at least 95 percent efficiency.

This section includes the following information for **medium** photo processors:

- silver recovery compliance options, and
- equipment configurations with testing and record keeping requirements.

4.1 Compliance Options

The following silver recovery options are recommended for recovering at least 95 percent of the silver from silver-rich solutions:

1. electrolytic unit followed by a chemical recovery cartridge (CRC) with manufacturer-specified flow control, or
2. two or more CRCs with manufacturer-specified flow control, or
3. precipitation unit, or
4. evaporation or distillation unit, or
5. off-site management, or
6. alternative technology providing at least 95 percent silver recovery.

4.2 Equipment Configurations

In this section for medium photo processors, we'll review typical silver recovery equipment configurations for each of the compliance options. Detailed information is available in the appendices.

We'll also describe the testing methods and procedures to use with the equipment to verify that it is recovering at least 95 percent of the silver.

Finally, we'll show you samples of simple silver recovery logs to use for recording the results of the testing.

If you are a medium photo processor, you **must select and use** one of the equipment configurations discussed in this section.

For detailed information about a specific type of silver recovery equipment, how it works, and preventive maintenance recommendations, refer to:

Appendix B Electrolytic Silver Recovery
 Appendix C Chemical Recovery Cartridges
 Appendix D Precipitation
 Appendix E Evaporation & Distillation
 Appendix F Off-Site Management

a. *Electrolytic unit followed by a chemical recovery cartridge (CRC) with manufacturer -specified flow control*

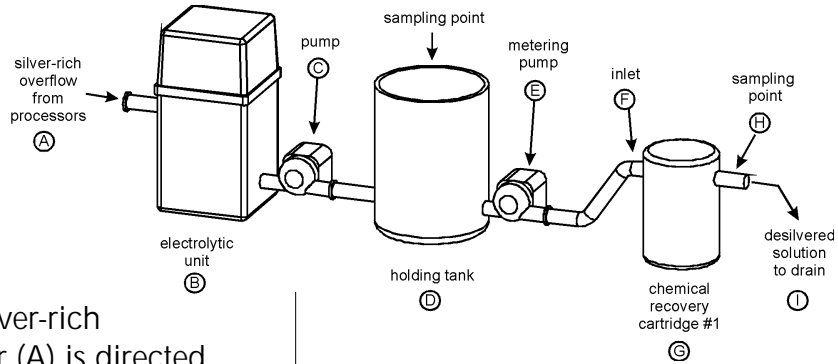

How it works

In this configuration, the silver-rich overflow from the processor (A) is directed to the electrolytic unit (B). When sufficient silver-rich solution has accumulated, the electrolytic unit begins to desilver the solution. When the batch is completed, the partially desilvered solution is pumped out of the electrolytic unit (C) into the holding tank (D). From here, it is metered (E) at a fixed rate through the chemical recovery cartridge (G). Once the solution exits the cartridge (H) at least 95 percent of the silver has been recovered and the solution can be discharged to the drain (I).

Testing methods

There are two types of testing methods you must use:

- **once each week**, silver-estimating test papers or another method of approximating silver must be used to indicate the system is working (pass/fail), and
- **once every six months**, highly accurate analytical laboratory testing such as atomic absorption (AA) or inductively coupled plasma spectroscopy (ICP) must be used. Use an outside service for analytical testing.

Testing procedures

Use the following testing procedures with this equipment configuration:

1. The solution coming out of the electrolytic unit (D) must be checked **weekly** with silver-estimating test papers. (See Appendix H for more information.)
2. The solution coming out of the CRC (H) must be checked **weekly** with silver-estimating test papers.
3. The solution going into the electrolytic unit (A) and coming out of the CRC (H) must be tested **once every six months** by an analytical laboratory. This testing is used to verify the percent efficiency of the system.

Testing records

- All test results must be recorded in a silver recovery log. See the examples below. Check with the POTW to find out how long to keep records on file.

Silver Recovery Log		
Date	Weekly Effluent Check*	
	Electrolytic	CRC
7/1/96	P	P
7/8/96	P	P
7/15/96	P	F

* Pass (P) = no color, Fail (F) = color

Silver Recovery Log (ppm)			
Date	Six Month Test		% Recovery
	Influent	Effluent	
7/5/96	1984	98	95.1%*
1/5/97			
7/1/97			

* To obtain the percent recovery, use the following formula:
 $100 - (\text{effluent} \times 100 \div \text{influent})$.

b. Two or more chemical recovery cartridges (CRCs) with manufacturer - specified flow control

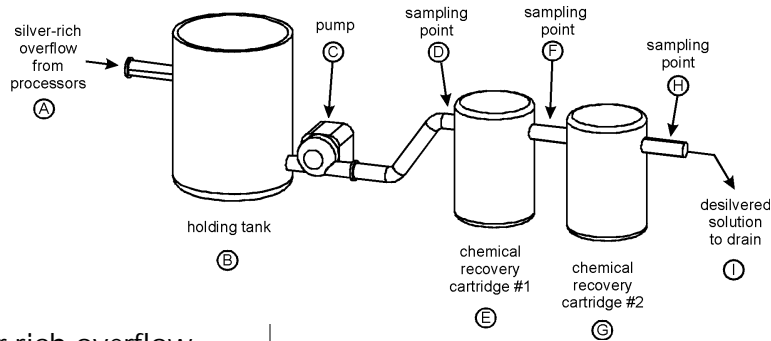

How it works

In this configuration, the silver-rich overflow from the processor (A) is directed to the holding tank (B). Next, it is metered (C) at a fixed rate through the chemical recovery cartridges (CRCs) set up in series (E - G). In this diagram two CRCs are shown. Once the solution exits the last cartridge in series (H) at least 95 percent of the silver has been recovered and the solution can be discharged to the drain (I).

Testing methods

There are two types of testing methods you must use:

- **once each week**, silver-estimating test papers or another method of approximating silver must be used to indicate the system is working (pass/fail), and
- **once every six months**, highly accurate analytical laboratory testing such as atomic absorption (AA) or inductively coupled plasma spectroscopy (ICP) must be used. Use an outside service for analytical testing. Review Appendix H for detailed information about testing.

Testing procedures

Use the following testing procedures with this equipment configuration:

1. The solution coming out of the first CRC (F) must be checked **weekly** with

silver-estimating test papers. (See Appendix H for more information.)

2. At the same time, the solution coming out of the second CRC (H) must be checked *weekly* with silver-estimating test papers.
3. The solution going into the first CRC (B) and coming out of the second CRC (H) must be tested *once every six months* by an analytical laboratory. This testing is used to verify the percent efficiency of the system.

Testing records

- All test results must be recorded in a silver recovery log. See the example below. Check with the POTW to find out how long to keep records on file.

Silver Recovery Log		
Date	Weekly Effluent Check*	
	CRC #1	CRC #2
7/1/96	P	P
7/8/96	P	P
7/15/96	F	P

* Pass (P) = no color, Fail (F) = color

When the weekly check indicates cartridge failure, refer to the equipment manual for the manufacturer's recommendations.

Silver Recovery Log (ppm)			
Date	Six Month Test		% Recovery
	Influent	Effluent	
7/5/96	1784	89	95.1%*
1/5/97			
7/5/98			

* To obtain the percent recovery, use the following formula:
 $100 - (\text{effluent} \times 100 \div \text{influent})$.

c. *Precipitation unit*

How it works

In this configuration, the silver-rich overflow from the processor (A) is directed to a collection tank inside the precipitation unit (B). Next, the solution is pumped from the collection tank through a coil where it is mixed with a precipitating agent. Silver-rich solids are formed and collected as a sludge in a filter inside the unit and sent off-site for silver recovery. The solution exiting the precipitation unit (C) can be discharged to the drain because at least 95 percent of the silver has been recovered.

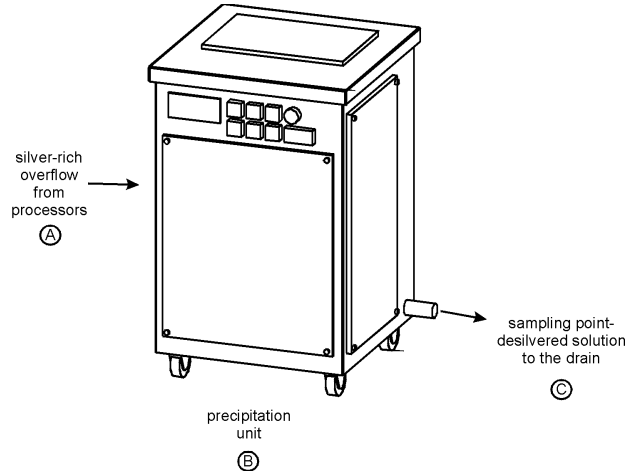

Testing methods

There are two types of testing methods you must use:

- **once each week**, silver-estimating test papers or another method of approximating silver must be used to indicate the system is working (pass/fail), and
- **once every six months**, highly accurate analytical laboratory testing such as atomic absorption (AA) or inductively coupled plasma spectroscopy (ICP) must be used. Use an outside service for analytical testing. Review Appendix H for detailed information about testing.

Testing procedures

Use the following testing procedures with this equipment configuration:

1. The solution coming out of the precipitation unit (C) must be checked **weekly** with silver-estimating test

papers. (See Appendix H for more information.)

2. The solution going into the precipitation unit (A) and coming out of the precipitation unit (C) must be tested **once every six months** by an analytical laboratory. This testing is used to verify the percent efficiency of the system.

Testing records

- All test results must be recorded in a silver recovery log. See the examples below. Check with the POTW to find out how long to keep records on file.

Date	Six Month Test		% Recovery
	Influent	Effluent	
7/5/96	1984	98	95.1%*
1/5/97			
7/5/98			

Date	Six Month Test		% Recovery
	Influent	Effluent	
7/5/96	1984	98	95.1%*
1/5/97			
7/5/98			

* To obtain the percent recovery, use the following formula:
 $100 - (\text{effluent} \times 100 \div \text{influent})$.

d. Evaporation or distillation unit

How it works

Evaporation and distillation may be used in conjunction with off-site management. Both of these processes concentrate and reduce the volume of overflow to be sent off-site, thus lowering the costs of hauling and treating the waste.

In this configuration, the silver-rich overflow from the processor (A) is directed into the evaporation or distillation unit (B). In evaporation, the liquid is evaporated leaving a silver-rich slurry that is collected in the unit and eventually sent off-site for treatment (C).

In distillation, the liquid portion of the overflow is heated to its boiling point. Then the vapors are captured and cooled resulting in a distillate of essentially distilled water. Since at least 95 percent of the silver has been recovered, the distillate can be discharged to the drain (D) or used to mix secondary chemicals. The remaining silver-rich slurry is collected in the unit and eventually sent off-site for treatment (C).

Testing methods

There are two types of testing methods you must use:

- **once each week**, silver-estimating test papers or another method of approximating silver must be used to indicate the system is working (pass/fail), and
- **once every six months**, highly accurate analytical laboratory testing such as atomic absorption (AA) or inductively coupled plasma spectroscopy (ICP) must be used. Use an outside service for analytical testing. Review Appendix H for detailed information about testing.

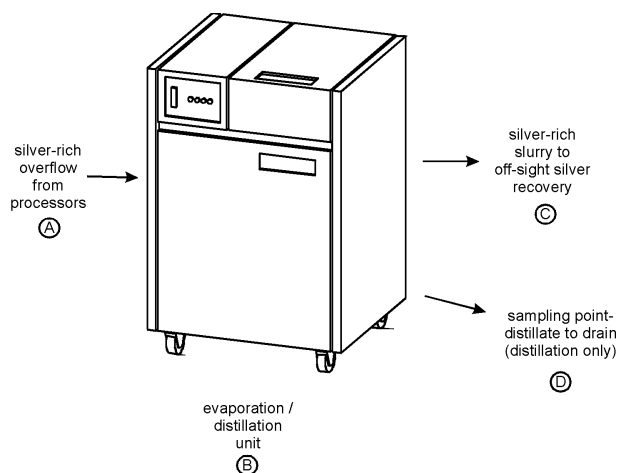

Testing procedures

Use the following testing procedures with this equipment configuration:

1. The solution coming out of the distillation unit (D) must be checked **weekly** with silver-estimating test papers.
2. The solution going into the distillation unit (A) and coming out of the distillation unit (D) must be tested **once every six months** by an analytical laboratory. This testing is used to verify the percent efficiency of the system.

If the system produces no effluent to the drain, no testing is required for the Code of Management Practice.

Testing records

- All test results must be recorded in a silver recovery log. See the examples below. Check with the POTW to find out how long to keep records on file.

Date	Weekly Effluent Check*
7/1/96	P
7/8/96	P
7/15/96	P

* Pass (P) = no color
Fail (F) = color

Date	Six Month Test		% Recovery
	Influent	Effluent	
7/5/96	1984	98	95.1%*
1/5/97			
7/5/98			

* To obtain the percent recovery, use the following formula:
100 - (effluent x 100 ÷ influent).

e. Off-site management

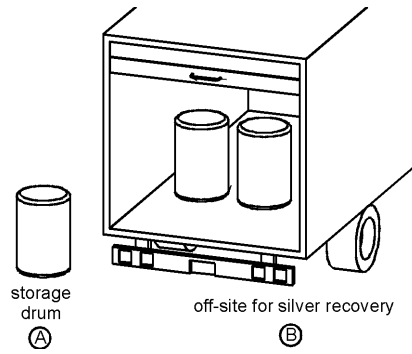

How it works

In this configuration, the silver-rich solution overflow from the processor is stored in a drum (A) until it is picked-up by a licensed hauler for off-site silver recovery, treatment and/or disposal (B).

Testing requirements

There are no Code of Management Practice testing requirements for verifying silver recovery efficiencies. State waste agencies, however, may require testing in order to characterize the waste.

Additional requirements

Photo processors using off-site management must meet the following requirements:

- Submit notification to the local sewage treatment authorities (e.g., POTW) that the processor is using off-site silver recovery. The POTW may require some specific information concerning the hauling and receiving facilities.
- Store the silver-rich solutions in a drum that's compatible with photo processing solutions.

- Provide secondary containment for storage tanks, if required in your jurisdiction.
- Comply with all applicable hazardous waste and DOT regulations.
- Keep records of volumes and types of solutions transferred off-site. See the example log below.
- Maintain logs and records for at least three years. Make the records available for inspection by the sewage treatment authorities.

Date	Amount (gallons)	Type of Solution	Manifest Number
2/6/96	44	silver - rich photo	MI 3084201
3/5/96	44	silver - rich photo	MI 3084202
4/2/96	55	silver - rich photo	MI 3084203
5/7/96	48	silver - rich photo	MI 3084204
6/4/96	55	silver - rich photo	MI 3084205

5.0 Large Photo Processors

A large photo processor is one that produces more than 20 gallons per day of silver-rich solutions and more than 10,000 gallons per day of total effluent. Large labs must recover silver to at least 99 percent efficiency.

This section includes the following information for **large photo** processors:

- silver recovery compliance options, and
- equipment configurations with testing and record keeping requirements.

5.1 Compliance Options

The following silver recovery options are recommended for recovering at least 99 percent of the silver from silver-rich solutions:

1. electrolytic unit followed by two or more chemical recovery cartridges (CRCs) with manufacturer-specified flow control, or
2. electrolytic unit followed by precipitation, or
3. evaporation or distillation unit, or
4. off-site management, or
5. alternative technology providing at least 99 percent silver recovery (e.g., ion exchange — see Appendix G).

5.2 Equipment Configurations

In this section for large photo processors, we'll review typical silver recovery equipment configurations for each of the compliance options. Detailed information is available in the appendices.

We'll also describe the testing methods and procedures to use with the equipment to verify that it is recovering at least 99 percent of the silver.

Finally, we'll show you samples of simple silver recovery logs to use for recording the results of the testing.

For detailed information about a specific type of silver recovery equipment, how it works, and preventive maintenance recommendations, refer to:

Appendix B Electrolytic Silver Recovery
 Appendix C Chemical Recovery Cartridges
 Appendix D Precipitation
 Appendix E Evaporation & Distillation
 Appendix F Off-Site Management
 Appendix G Ion Exchange

a. *Electrolytic unit followed by two or more chemical recovery cartridges (CRC) with manufacturer -specified flow control*

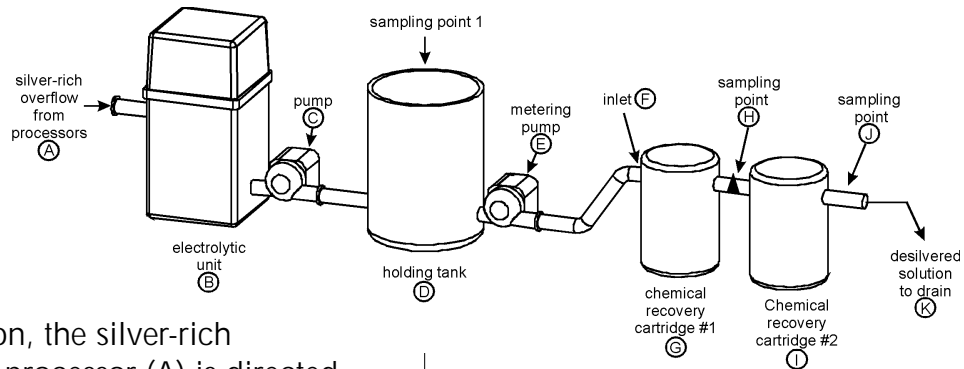

How it works

In this configuration, the silver-rich overflow from the processor (A) is directed to the electrolytic unit (B). When sufficient silver-rich solution has accumulated, the electrolytic unit begins to desilver the solution. When the batch is completed, the partially desilvered solution is pumped out of the electrolytic unit (C) into the holding tank (D). From here, it is metered (E) at a fixed rate through the CRCs (G, J). Once the solution exits the last CRC (I) at least 99 percent of the silver has been recovered and the solution can be discharged to the drain (K).

Testing methods

There are two types of testing methods you must use:

- **once each week**, silver-estimating test papers or another method of approximating silver must be used to indicate the system is working (pass/fail), and
- **once every three months**, highly accurate analytical laboratory testing such as atomic absorption (AA) or inductively coupled plasma spectroscopy (ICP) must be used. Use an outside service for analytical testing. Review Appendix H for detailed information about testing.

Testing procedures

Use the following testing procedures with this equipment configuration:

1. The solution coming out of the electrolytic unit (D) must be checked **weekly** with silver-estimating test papers. (See Appendix H for more information.)
2. The solution coming out of the first (H) and last CRCs (J) must be checked **weekly** with silver-estimating test papers.
3. The solution going into the electrolytic unit (A) and coming out of the last CRC (J) must be tested **once every three months** by an analytical laboratory. This testing is used to verify the percent efficiency of the system.

Testing records

- All test results must be recorded in a silver recovery log. See the example below. Check with the POTW to find out how long to keep records on file.

Silver Recovery Log			
Date	Weekly Effluent Check*		
	Electrolytic	CRC #1	CRC #2
7/1/96	P	P	P
7/8/96	P	P	P
7/15/96	P	F	P

* Pass (P) = no color, Fail (F) = color

Silver Recovery Log (ppm)			
Date	Three Month Test		% Recovery
	Influent	Effluent	
7/5/96	1876	17	99.1%*
10/5/96	2016	18	99.1%
1/5/97			

* To obtain the percent recovery, use the following formula:
 $100 - (\text{effluent} \times 100 \div \text{influent})$.

b. Electrolytic unit followed by precipitation

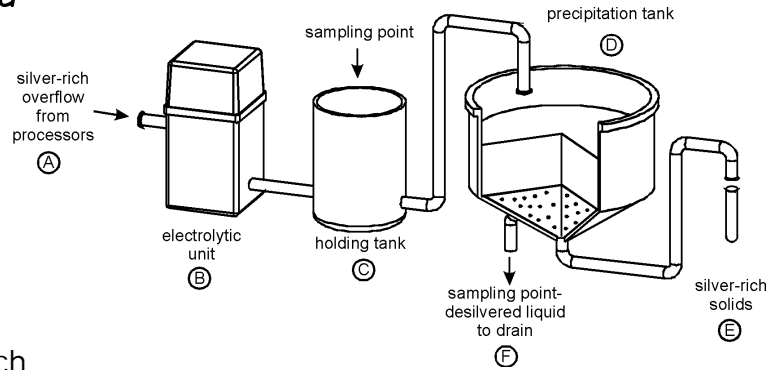

How it works

In this configuration, the silver-rich overflow from the processor (A) is directed to the electrolytic unit (B) where a significant amount of the silver is recovered. From here, it is pumped into a holding tank (C). When sufficient volume has collected for a batch, the solution is pumped into the precipitation tank (D) where silver-rich solids are precipitated and pumped out into a filter bag (E) for collection. The remaining liquid can be discharged to the drain (F) because at least 99 percent of the silver has been removed.

Testing methods

There are two types of testing methods you must use:

- **once each week**, silver-estimating test papers or another method of approximating silver must be used to indicate the system is working (pass/fail), and
- **once every three months**, highly accurate analytical laboratory testing such as atomic absorption (AA) or inductively coupled plasma spectroscopy (ICP) must be used. Use an outside service for analytical testing. Review Appendix H for detailed information about testing.

Testing procedures

Use the following testing procedures with this equipment configuration:

1. The solution coming out of the electrolytic unit (C) must be checked **weekly** with silver-estimating test papers. (See Appendix H for more information.)
2. The solution coming out of the precipitation tank (F) must be checked **weekly** with silver-estimating test papers.
3. The solution going into the electrolytic unit (A) and coming out of the precipitation tank (F) must be tested **once every three months** by an analytical laboratory. This testing is used to verify the percent efficiency of the system.

Testing records

- All test results must be recorded in a silver recovery log. See the examples below. Check with the POTW to find out how long to keep records on file.

Silver Recovery Log		
Date	Weekly Effluent Check*	
	Electrolytic	Precipitation
7/1/96	P	P
7/8/96	P	P
7/15/96	P	P

* Pass (P) = no color, Fail (F) = color

Silver Recovery Log (ppm)			
Date	Three Month Test		% Recovery
	Influent	Effluent	
7/5/96	1876	17	99.1%*
10/5/96	2016	18	99.1%
1/5/97			

* To obtain the percent recovery, use the following formula:
 $100 - (\text{effluent} \times 100 \div \text{influent})$

c. Evaporation or distillation unit

How it works

Evaporation and distillation may be used in conjunction with off-site management. Both of these processes concentrate and reduce the volume of overflow to be sent off-site, thus lowering the costs of hauling and treating the waste.

In this configuration, the silver-rich overflow from the processor (A) is directed into the evaporation or distillation unit (B). In evaporation, the liquid is evaporated leaving a silver-rich slurry that is collected in the unit and eventually sent off-site for treatment (C).

In distillation, the liquid portion of the overflow is heated to its boiling point. Then the vapors are captured and cooled resulting in a distillate of essentially distilled water. Since at least 99 percent of the silver has been recovered, the distillate can be discharged to the drain (D) or used to mix secondary chemicals. The remaining silver-rich slurry is collected in the unit and eventually sent off-site for treatment (C).

Testing methods

There are two types of testing methods you must use:

- **once each week**, silver-estimating test papers or another method of approximating silver must be used to indicate the system is working (pass/fail), and
- **once every three months**, highly accurate analytical laboratory testing such as atomic absorption (AA) or inductively coupled plasma spectroscopy (ICP) must be used. Use an outside service for analytical testing.

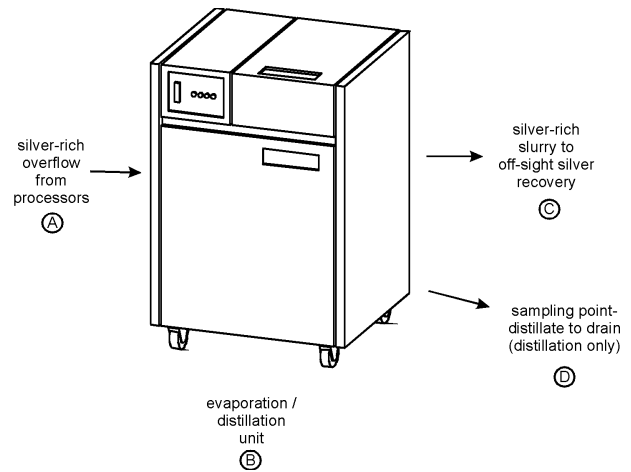

Testing procedures

Use the following testing procedures with this equipment configuration:

1. The solution coming out of the distillation unit (D) must be checked **weekly** with silver-estimating test papers.
2. The solution going into the distillation unit (A) and coming out of the distillation unit (D) must be tested **once every three months** by an analytical laboratory. This testing is used to verify the percent efficiency of the system.

If the system produces no effluent to the drain, no testing is required for the Code of Management Practice.

Testing records

- All test results must be recorded in a silver recovery log. See the examples below. Check with the POTW to find out how long to keep records on file.

Silver Recovery Log	
Date	Weekly Effluent Check*
7/1/96	P
7/8/96	P
7/15/96	P

* Pass (P) = no color
Fail (F) = color

Silver Recovery Log (ppm)			
Date	Three Month Test		% Recovery
	Influent	Effluent	
7/5/96	1876	17	99.1%*
10/5/96	2016	18	99.1%
1/5/98			

* To obtain the percent recovery, use the following formula:
 $100 - (\text{effluent} \times 100 \div \text{influent})$.

d. Off-site management

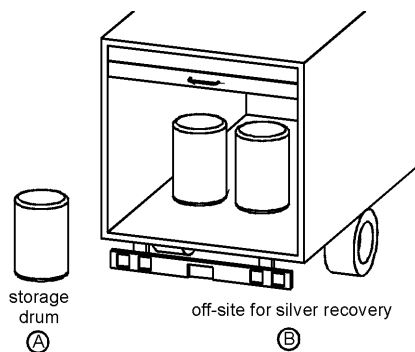

How it works

In this configuration, the silver-rich solution overflow from the processor is stored in a drum (A) until it is picked-up by a licensed hauler for off-site silver recovery, treatment and/or disposal (B).

Testing requirements

There are no Code of Management Practice testing requirements for verifying silver recovery efficiencies. State waste agencies, however, may require testing in order to characterize the waste.

Additional requirements

Photo processors using off-site management must meet the following requirements:

- Submit notification to the local sewage treatment authorities (e.g., POTW) that the processor is using off-site silver recovery. The POTW may require some specific information concerning the hauling and receiving facilities.
- Store the silver-rich solutions in a drum that's compatible with photo processing solutions.

- Provide secondary containment for storage tanks, if required in your jurisdiction.
- Comply with all applicable hazardous waste and DOT regulations.
- Keep records of volumes and types of solutions transferred off-site. See the example log below.
- Maintain logs and records for at least three years. Make the records available for inspection by the sewage treatment authorities.

Off-Site Chemical Log			
Date	Amount (gallons)	Type of Solution	Manifest Number
2/6/96	44	silver - rich photo	MI 3084201
3/5/96	44	silver - rich photo	MI 3084202
4/2/96	55	silver - rich photo	MI 3084203
5/7/96	48	silver - rich photo	MI 3084204
6/4/96	55	silver - rich photo	MI 3084205

1.0 Pollution Prevention

The photographic industry has a long history of practicing waste minimization, whether it's through the use of photo processing solutions with reduced replenishment rates or recycling single-use cameras. Using good waste control practices has two benefits: we can lower the impact our businesses have on the environment and we can save money through reduced materials and labor.

In today's language, waste control is called *pollution prevention*. Pollution prevention, or *P2* as it's better known, is the name given to good management practices, as well as equipment and chemical modifications that result in reducing or eliminating waste.

Most photo processors are already using some pollution prevention practices. In this section of the Code of Management Practice Guide for Photo Processors we're going to give you a method to look at your whole facility, identify options for pollution prevention, put a P2 plan in place, and follow-up on the success of that plan.

Planning for Pollution Prevention

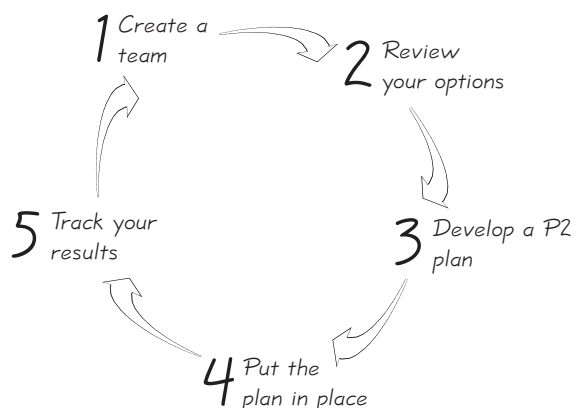

The diagram on the left shows the five steps of P2 planning:

- 1. Create a team** of interested and capable staff and management employees to develop and oversee pollution prevention in your facility.
- 2. Review your options** by examining your current practices in light of alternative or additional measures that can reduce or eliminate waste.
- 3. Develop a P2 plan** by deciding which options you'll adopt, the time frame for adopting them, and who will be responsible for overseeing implementation and maintenance of the option.
- 4. Put the plan in place** by providing the staff with pollution prevention training and resources.
- 5. Track your results** by keeping records where they are helpful and by routinely auditing or inspecting your photo lab for pollution prevention.

Not every pollution prevention activity discussed in this section will make sense for your facility. For example, while low replenishment rate photo processing solutions reduce the amount of effluent to drain, some labs don't have a high enough roll volume to be able to use these solutions. This is just one example of why it's so important for you to conduct a thorough review of your facility and examine your options before you begin to develop a P2 plan.

In the following pages of this section, we provide you with specific P2 information and checklists to assess your performance.

1.1 Put a Team Together

Commitment from management and staff is an essential element of a successful pollution prevention plan.

Management shows its support by:

1) developing, implementing and maintaining a P2 policy, 2) forming a P2 team, and 3) by allowing adequate time and resources for P2 activities.

Staff shows its support by working with management to ensure pollution prevention is a priority in the photo lab.

a. Management activities

There's no substitution for good leadership in pollution prevention. Management has a key role to play.

A pollution prevention policy

A pollution prevention policy is a simple and clear statement that waste reduction and elimination are goals of your company. The policy can be developed with the help of the P2 team (discussed next). At the top of the next column we've provided an example of a policy. Make sure it's signed by a manager to show commitment and responsibility for P2 activities.

Once the policy is developed, it should be posted for all employees, and perhaps even customers, to see. Remember — the success of P2 depends upon support from all the people in the photo lab.

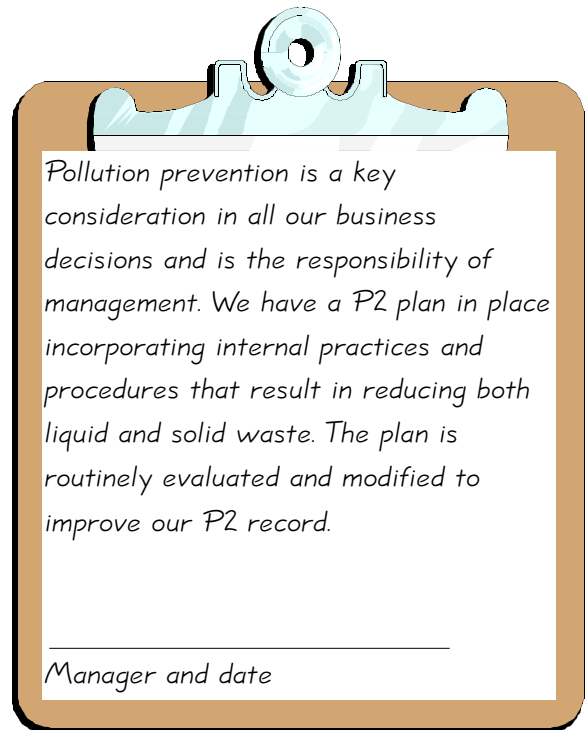

The P2 team

The pollution prevention team is the group of management and staff people who develop, implement and evaluate all the activities that go into making up the P2 plan.

- *How many people should be on the team?* That depends upon the size of your lab. In a three or four person minilab, it might be a team of one — the manager. In a large wholesale lab, it might be a team of five or six. You decide how many people you need.

- *Who makes the best team member?* The best team member is someone who's interested in pollution prevention, who wants to be on the team and who has a good understanding of the entire photo processing system.

- *What about a team leader?* The P2 team needs a leader. Management can leave that decision up to the team or it can designate someone.

Time and resources for the P2 team

The P2 team needs time and resources to do its job properly. Time means time to meet, audit the facility, develop the P2 plan, put it into action, and periodically evaluate it. Resources mean training and technical information such as roll counts and replenishment rates. Management must provide these as part of its commitment to P2.

b. Staff activities

Everyone has a part to play in pollution prevention. Some staff will be part of the P2 team. Their responsibilities will be to help develop the P2 plan and put it in place.

Train other staff to recognize pollution prevention opportunities and to minimize waste where ever it's possible.

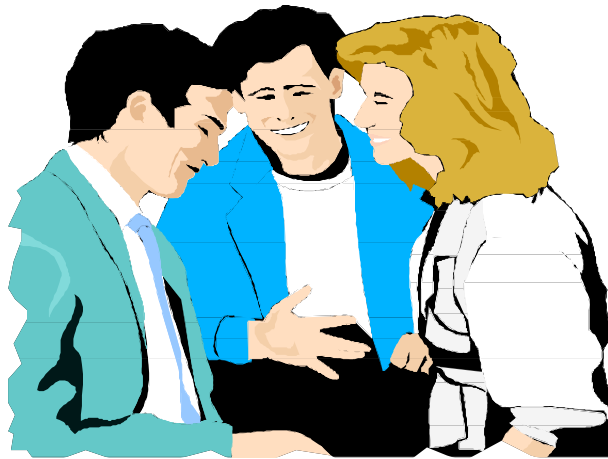

Checklist

This checklist reviews all the elements for putting together a P2 team. When you have the team in place, you should be able to answer "Yes" to all questions. "No" answers are potential pollution prevention opportunities. When you don't have adequate information to answer, mark the "?" Then get the information you need to make an assessment.

<i>Pollution Prevention Team</i>			
	Yes	No	?
• Do you have a P2 policy?			
• Has it been signed and dated by a manager?			
• Is the policy posted where all employees can see it?			
• Have employees been told about the P2 policy and its purpose?			
• Has the P2 team been formed?			
• Are the team members knowledgeable about photo processing?			
• Has a team leader been chosen?			
• Does management provide the team with the time and resources needed for P2 planning and implementation?			

1.2 Review Your Options

Pollution prevention options for photo processing solutions can be broken into three categories: 1) management practices, 2) equipment modifications, and 3) process modifications. Each of these will be examined here. We'll also look at options for managing the solid waste produced in a photo lab.

At this phase of the P2 process, we're only *looking* at the options. After each discussion, we've included a checklist for you to evaluate your practices and equipment. Anytime you answer "No" you've found a potential pollution prevention opportunity. Anytime you answer "?" it means you need more information to evaluate the option.

a. Management practices

Some of the simplest and least expensive management practices produce the most effective pollution prevention results. Keep this in mind as we look at the following management practices.

Preventive maintenance

Preventive maintenance should be your first pollution prevention option. By implementing a complete preventive maintenance program, the equipment will work at its optimum level, keeping waste at a minimum. Use the recommendations found in the equipment operating manual as a starting point for your preventive maintenance program.

Process control

Process control is the routine monitoring of variables that affect the quality of your product. These variables include:

- replenishment rates,
- processing temperatures, and
- chemical mix procedures.

To ensure these variables remain constant they must be checked periodically.

In addition to monitoring these variables on a set schedule, the photo processor **must** routinely run control strips, chart the results of each strip (as shown on the chart below) and take action based on the results.

Example process control chart

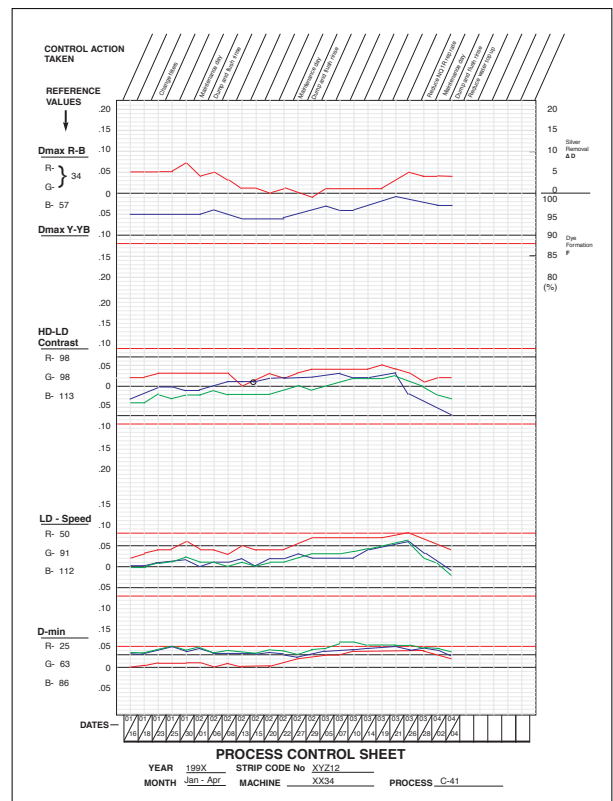

Inventory control

Managing the chemical inventory includes rotating the stock so that the oldest is used first and maintaining an appropriate supply of chemicals on-hand. This reduces the risk of having old chemicals in inventory and reduces the amount of money tied-up in stock.

Spill response planning

Any time a solution is unintentionally released it's a spill. The key word is **unintentional**. When you produce a waste solution during rack washing, it's intentional. When you replace the rinse or stabilizer tank solution according to manufacturer recommendations, the waste solution you produce is intentional. Neither of these examples, therefore, is a spill.

But if a container of photo processing solution is dropped on the floor, ruptures and leaks, you now have a spill.

Most spills are minor splashes or leaks and can be cleaned up with a sponge or mop. Occasionally, however, a larger spill could occur requiring specialized clean-up materials and procedures.

The time to plan for a spill is long before it happens. A good spill response plan will help minimize the effects of the spill and ensure the photo lab returns to normal as quickly as possible. Some of the things to include in your spill response plan are:

- an inventory of all the chemicals used in the photo lab;
- a floor plan showing the location of all chemicals in the photo lab, floor drains, exits, fire extinguishers, and spill response supplies;
- a description of the containment used for silver recovery cartridges, mixing tanks, chemical storage tanks, and any other containers that could leak or rupture;
- a list of spill response supplies and equipment such as mop, pail, sponge,

co-polymer and other absorbent materials, personal protective equipment; and

- a set of tested procedures for responding to a spill. A sample spill response procedure is included in Appendix I.

Good housekeeping

In a clean and orderly photo lab, there's better control over materials and equipment and less likelihood of spills. This results in less operational waste and prevents pollution.

Good housekeeping is one of those inexpensive and simple management practices that can significantly reduce waste, increase productivity and lower costs. You can't afford to neglect it. Here are three basic good housekeeping guidelines:

1. Designate an appropriate storage area for all materials and every piece of equipment.
2. Require every employee (including yourself) to return all materials and equipment to their designated area.
3. Establish a procedure and a schedule to inspect chemical receiving, storage, mixing and use areas for spills, leaks, cleanliness, and orderliness. Ensure all areas are clean.

Safety and security

Keeping chemical areas safe and secure can minimize spills and other upsets.

- Make sure there is always someone trained in spill response procedures in the facility.

- Restrict admittance to areas where chemicals are used and stored to those who have had hazard communication training.
- Make sure there's an MSDS on file for every chemical in the facility.
- Maintain a security system so that you know when someone is in the facility.

Checklist

This checklist reviews all the elements for evaluating management practices. "Yes" answers indicate that you're already using that pollution prevention measure. "No" answers are potential pollution prevention opportunities. When you don't have adequate information to answer, mark the "?" Then get the information you need to make an assessment.

<i>Management Practices</i>			
<i>Preventive Maintenance</i>	Yes	No	?
<ul style="list-style-type: none"> Is there a preventive maintenance program in place incorporating all the equipment manufacturer recommendations? 			
<i>Process Control</i>	Yes	No	?
<ul style="list-style-type: none"> Are solution replenishment rates routinely monitored? Are processing tank temperatures routinely checked? Are standard chemical mix procedures used by all staff? Are control strips run on processors at least once per shift? Are all control strips plotted on control charts? When corrective action is taken, is it noted on the control chart? 			
<i>Inventory Control</i>	Yes	No	?
<ul style="list-style-type: none"> Is the oldest chemical stock always used first? Are appropriate levels of stock maintained? 			
<i>Spill Response Planning</i>	Yes	No	?
<ul style="list-style-type: none"> Is there a spill response plan? Is it posted in the chemical mix area? Is there an inventory of all chemicals in the photo lab? Is there a floor plan detailing the location of chemicals, floor drains, exits, fire extinguishers and spill response supplies? Is there containment around all permanent chemical containers? Are the spill response supplies easily accessible? 			

<i>Management Practices (continued)</i>			
<i>Good housekeeping</i>	Yes	No	?
• Are all materials and equipment kept in a specified location?			
• Are all chemical containers routinely checked for cracks or leaks?			
• Is all equipment wiped clean of chemical residue and dirt?			
• Are all floors free of chemical spills and residue?			
• Are aisles and walkways clear?			
• Does the photo lab look orderly and clean?			
• Are all employees held accountable for good housekeeping?			
<i>Safety and Security</i>	Yes	No	?
• Is there at least one staff member trained in spill response in the facility at all times?			
• Are areas where chemicals are used and stored restricted to staff trained in safe chemical handling?			
• Is there an MSDS for every chemical in the facility?			
• Is there a security system for off-hours?			

b. Equipment modifications

A second category of pollution prevention options is equipment modifications. This refers to the changes made to film and paper processors to reduce the amount of waste solution produced through photo processing. As we examine each of these options remember what we said earlier:

Not every one of these options is appropriate for your equipment. In some cases, equipment cannot be modified. Check with your equipment manufacturer.

Squeegees

Squeegees are an inexpensive and effective P2 option that improves silver recovery. As film exits the fix tank or paper exits the bleach-fix tank, it carries over a certain amount of silver-rich solution into the wash. A squeegee reduces carryover, therefore keeping the silver in the fix or bleach-fix tank where the overflow can be sent to silver recovery instead of being lost in the wash tanks.

In-line silver recovery

Another way to reduce the silver carried over from the fix tank into the wash tanks is to reduce the concentration of silver in the fix. This can be done with in-line silver recovery.

In-line silver recovery is an electrolytic unit through which the fix in the processor tank is recirculated. This significantly reduces the concentration of silver carried over into the wash.

There are other benefits of in-line silver recovery. Generally, it's possible to use a lower fix replenishment rate which means lower chemical consumption.

Additionally, the silver recovered is high grade silver flake.

If you use in-line silver recovery, check with your chemical supplier to determine if you need a specially formulated fix.

Counter-current wash tanks

Counter-current wash tanks are another equipment modification used to control silver. Counter-current plumbing is the practice of plumbing the series of final wash/rinse tanks so that the water enters the last tank first and the overflow cascades backward. The tank closest to the fix, therefore, has the least amount of fresh water and the highest concentration of silver. This makes it easier to recover the silver from the solution as well as reduces the amount of water required in the process.

Low-flow wash

Silver in the wash water may be further concentrated by using a low-flow or replenished wash immediately following the bleach-fix or fix tank, but prior to the final wash/rinse tanks. The low-flow wash tank is replenished and is separate from the wash/rinse tanks that follow it. Overflow from the low-flow wash tank should be combined with other silver-rich solutions for silver recovery.

Checklist

This checklist reviews all the elements for evaluating equipment modifications. "Yes" answers indicate that you're already using that pollution prevention measure. "No" answers are potential pollution prevention opportunities. When you don't have adequate information to answer, mark the "?" Then get the information you need to make an assessment.

<i>Equipment modifications</i>			
<i>Squeegees</i>	Yes	No	?
• Are there squeegees on all processors capable of being equipped?			
• Are all squeegees routinely checked and replaced when required?			
• Are all squeegees cleaned as part of the shut-down procedure?			
<i>In-line Silver Recovery</i>	Yes	No	?
• Is there an in-line electrolytic unit on all film fix tanks?			
• Is the silver concentration in the tank monitored so that it doesn't get below 500 ppm or above 1,000 ppm?			
• Is the fix specially designed for in-line silver recovery?			
• Has the fix replenishment rate been reduced?			
<i>Counter-current Wash Tanks</i>	Yes	No	?
• Are the processors equipped with counter-current wash tanks?			
<i>Low-flow Wash</i>	Yes	No	?
• Are the processors equipped with low-flow wash tanks?			
• Is the low-flow wash sent for silver-recovery?			

c. Process modifications

The third category of pollution prevention options is process modifications. Just as with equipment modifications, not all processors can be changed to accommodate every one of these process modifications.

Low replenishment chemicals

Replenishment rates have decreased dramatically over the past 10 years. Using chemicals with a low replenishment rate results in less overflow produced, and, therefore, less solution for silver recovery and discharge. In some cases, older equipment can't be modified to use new processes. And where roll volumes are low, the photo processor may not be able to use low replenishment chemicals.

Solution regeneration and reuse

Regenerating and reusing photo processing solutions may reduce the amount of chemicals to be desilvered or discharged to the drain. If the equipment can be modified and the roll counts are high enough, these pollution prevention options can significantly reduce waste.

Washless processing

Converting to washless processing is one of the most effective means of conserving water. With this process modification, the wash water is replaced with a chemical rinse that replenishes at a much lower rate than the water. This means that water is conserved and a lower overall volume of effluent is produced. While the concentration is higher, the loading is the same.

Water reuse and recycling

Reducing the amount of water used in photo processing reduces waste and conserves a valuable resource. Optional process modifications for water conservation include:

- multiple wash tanks with counter-current flow, and
- manufacturer kits such as metered wash water replenishment and wash water timers.

Because wash water has a direct affect on image stability, always consult with your manufacturer before making water conservation modifications to the processors.

Dry chemicals and automated mixing

Under some conditions, dry chemical packaging and automated mixing can contribute to waste minimization through extended shelf life and fewer mixing errors.

Checklist

This checklist reviews all the elements for evaluating process modifications. "Yes" answers indicate that you're already using that pollution prevention measure. "No" answers are potential pollution prevention opportunities. When you don't have adequate information to answer, mark the "?" Then get the information you need to make an assessment.

<i>Process modifications</i>			
<i>Replenishment</i>	Yes	No	?
• Are low replenishment chemicals used where it's practical?			
• Have replenishment rates been adjusted to reflect the lower requirements?			
<i>Solution Regeneration and Reuse</i>	Yes	No	?
• Are chemicals regenerated where it's practical?			
• Is the portion of the silver-rich chemicals that is not regenerated sent for silver recovery?			
• Are chemicals reused where it's practical?			
<i>Washless Processing</i>	Yes	No	?
• Has all equipment been converted to washless?			
• Is the chemical rinse sent for silver recovery?			
<i>Water Reuse and Recycling</i>	Yes	No	?
• Are wash water rates set at the manufacturer recommendations?			
• Does the wash water run only during processing?			
• Is a wash water conservation kit used? (e.g., metered wash water replenishment or wash water timer)			
<i>Other Process Modifications</i>	Yes	No	?
• Are dry chemicals used where it's practical?			
• Are automated mixers used where it's practical?			

d. Solid waste

There are many pollution prevention opportunities for reducing the solid waste produced in a photo lab. For example, single-use cameras and the metal and plastic from film canisters and cassettes can be recycled. Batteries, paper bags, paper cores, and film canisters can be reused.

These are just a few of the items. Most manufacturers have take-back programs for the solid materials used in the manufacturing and packaging of their products. Malls and building owners have recycling programs for corrugated cardboard, office paper and other materials. Reusing and recycling reduces the amount of solid waste going to landfill and lowers your waste disposal fees.



Checklist

This checklist reviews all the elements for evaluating your solid waste management program. "Yes" answers indicate that you're already using that pollution prevention measure. "No" answers are potential pollution prevention opportunities. When you don't have adequate information to answer, mark the "?" Then get the information you need to make an assessment.

<i>Solid Waste</i>			
<i>Are the following solid wastes reused:</i>	Yes	No	?
• Batteries?			
• Film canisters?			
• Plastic core protectors?			
• Paper cores (cardboard)?			
• Photographic paper bags?			
• Processing equipment filters?			
• Packing materials including pallets and plastic wrap?			
<i>Are the following solid wastes recycled:</i>	Yes	No	?
• Single-use cameras?			
• Plastic film canisters?			
• Chemical containers?			
• Plastic film spools and cartridges?			
• Metal film cartridges?			
• Film leaders and trailers?			
• Plastic core protectors?			
• Paper cores (cardboard)?			
• Office paper?			
• Corrugated cardboard?			
• Box board?			
• Packing materials including pallets and plastic wrap?			

1.3 Develop a P2 Plan

Now that the P2 team has finished the audit or review, it's time for them to look at all the options and prioritize them as:

- **High priority** — needs immediate action
- **Medium priority** — needs action within 3 to 12 months
- **Low priority** — needs consideration within the next 1 to 2 years

Screening your options

Screen each option by asking the following questions and writing out your answers:

1. What is the potential for reducing waste and providing other environmental benefits?
2. What is it going to cost in time and materials?
3. How much money will it save in time and materials?
4. How difficult is it to implement?

To show you how this works, look at the following example of screening the option of using squeegees on a paper processor. A blank worksheet is included in Appendix I. Make copies as you need them and leave the original in this Guide.

Worksheet for Screening Options

Date _____

Option: Installing and maintaining squeegees on the paper processor

1. **What is the potential for reducing waste and providing other environmental benefits?**
Less silver will be lost to the wash tank and therefore the drain. In addition, we may be able to reduce replenishment rates.
2. **What is it going to cost in time and materials?**
Cost of the squeegees, replacement squeegees, brackets for the processor, labor for installation and periodic replacement, and labor for daily cleaning. (Estimate actual costs as closely as possible.)
3. **How much money will it save in time and materials?**
The savings will be realized in the increased amount of silver recovered. (Estimate actual savings as closely as possible.)
4. **How difficult is it to implement?**
Not difficult - we can schedule the installment during the next preventive maintenance check on the machine. We need to buy the squeegees and brackets. We also need to train process operators to keep the squeegees clean so we don't scratch paper.

Screening all the options you've identified will take time, but it's time well spent. It's very important that you actually write out your answers. Doing your homework here makes the difference between a P2 plan that exists only in your head vs. one that is implemented and working.

Point system

You might find it useful to develop a point system for rating all the options. For example, you could assign a *plus* value to every potential benefit and a *minus* value to every negative impact.

Writing the P2 plan

Whatever system you use, you need to get to the point where you've prioritized all of the options. Now you can begin to draft the P2 plan. For your first attempt at systematic pollution prevention, we recommend that you start with only the **high priority** options. Work at getting

these into place and evaluate your success before addressing the medium and low priority options. Don't make too many changes at once — start with only 3 or 4 items.

Keep your P2 plan simple. Here is the information you should include:

- **Spell out each option and its purpose**
- **State a specific date when the option will be implemented**
- **List who is responsible**
- **Note if a record will be kept**

Review the example below. A blank Pollution Prevention Plan Worksheet is included in Appendix I. Make copies as you need them and leave the original in this Guide.

Pollution Prevention Plan Worksheet	Date _____
Option or activity:	We're going to install squeegees on the paper processor in order to _____ reduce the amount of silver in the wash water. _____
Implementation date:	The squeegees will be installed during the December preventive _____ maintenance check. _____
Responsibility:	Joe Smith, maintenance supervisor, will arrange for buying the squeegees _____ and brackets, ensure the squeegees are installed and be responsible for _____ seeing they are maintained. He will also train the process operators how _____ to clean the squeegees and inspect them for wear. _____
Record:	Squeegee maintenance will be added to the preventive maintenance checklist. _____

1.4 Put the Plan in Place

Now that you have a P2 plan it's time to put it into action. These are the steps:

1. Make the plan known - Post it, explain its purpose and details to the employees, and talk it up. Through both your words and actions, make all employees aware of how committed the company is to pollution prevention. Keep employees updated on both the successes and failures of the plan.
2. Provide training and education - Make sure that anyone who is given responsibility in the P2 plan has the training and knowledge to carry out his/her tasks.
3. Provide the necessary resources - Make sure that anyone who is given responsibility in the P2 plan has the time and materials required to fully implement the P2 plan.

1.5 Track Your Results

Your P2 plan isn't a "Now I've done it so I can forget about it" kind of thing. You

need to periodically review it, evaluate which elements are working, which need to be modified, and which need to be discontinued. A review every six months should be often enough.

As you evaluate your P2 plan, keep in mind your original intent for pollution prevention: minimizing or eliminating waste for both environmental and economic benefit.

Answer each of the following questions for each pollution prevention option or activity listed in your plan:

- **How much waste has been reduced or eliminated as a result of this activity?**
- **How much has it cost?**
- **How much money has it saved?**

In some cases, it may be hard to get exact answers to these questions. But try. It's important that you fully evaluate every P2 option implemented in your photo lab. Once again, let's look at installing squeegees as an example.

Worksheet for Evaluating P2

Date _____

Option: Installing and maintaining squeegees on the paper processor

1. Waste reduction results

Using colorimetric testing, we found the concentration of silver in the first wash tank went from 95 ppm to 28 ppm. Over the 6 month period, we estimate this at 386 troy ounces of silver.

2. Costs

Materials - brackets and squeegees = \$240. Labor - installation 1 1/2 hours x \$20/hour = \$30.
Daily maintenance - 1 minute at \$12/hour = \$.20 daily or \$24 for 6 months. Total costs = \$294

3. Savings

386 tr. oz. of silver at \$5.40 tr. oz. = \$2,084. This was the amount of silver diverted from the wash.

A *successful* P2 option or activity is one that reduces waste and saves more money than it costs. Consider whether changing it would make it even more successful or whether to let it continue as is.

An *unsuccessful* option or activity is one that doesn't reduce waste, or it costs more money than it saves. With an unsuccessful option, consider whether changing it would make it successful or whether to discontinue using it.

Once you've done this evaluation for every option, you can also consider whether it's time to put some of those **medium priority** options in place. Remember not to make too many changes at once.

Spread the word

Every time you evaluate the success of the P2 plan, let the staff know the results — both the positive and the not so positive. When you decide to make changes or implement new P2 activities, remember to train the staff if there are any new procedures.

With pollution prevention, everyone's a winner: the impact of your business on the environment is reduced and the cost savings from lower waste means more money in your pocket.

P2